

STROBE

PRODUCT SHEET & SPECIFICATIONS

STROBE

(MODELS: STROBE-AMB,
STROBE-BL, STROBE-RED,
STROBE-GR, STROBE-WH)



DESCRIPTION

The strobes visual signals are heavy duty, reliable, UL, cUL (General Utility) (misc. device/control unit accessory) beacons. The strobes feature a UL listed Type 4X enclosure. They come in a steady-on mode, and can easily be set to a 65 fpm flashing mode. The base is manufactured from glass-reinforced thermoplastic polyester resin and the double fresnel lens is made of shatter resistant polycarbonate.

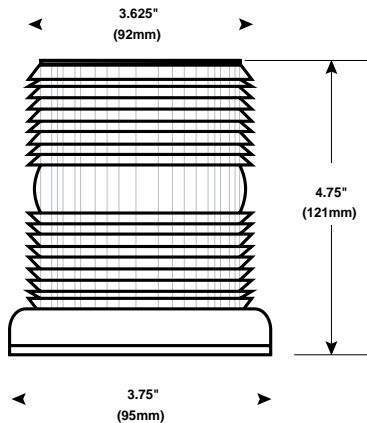

- FEATURES AND CAPABILITIES

- + 65 fpm mode field-selectable via dipswitch
- + Immune to shock and vibration
- + 31°F to 212°F (-35° to 100°C) operating temperature
- + LED Colors- Amber, Blue, Green, Red, White
- + Projected LED Life- 148,000 hours
- + Operating Voltage- 24V DC
- + Current- 0.215A
- + UL Listed